



Blackbody accuracy with a cost-effective design

Output Options

- **SP-710-SS Analog Albedometer Sensor Package:** SP-510-SS thermopile pyranometer, SP-610-SS thermopile pyranometer, AY-001 differential splitter, AW-605-SS 5 m cable
- **SP-722-SS Modbus Albedometer**



Apogee's new modbus albedometer is a cost-effective solution for horizontal and plane of array performance monitoring of bifacial solar panels. The SP-722-SS can be easily mounted to a mast or directly to a solar panel with one of the available mounting brackets.

Product Specifications

	SP-510	SP-610	SP-722 Upward-looking	SP-722 Downward-looking
ISO 9060:2018	Class C	N/A	Class C	N/A
Power Supply	—		5.5 to 24 V	
Current Draw	—		RS-232 quiescent 37 mA, active 37 mA; RS-485 quiescent 37 mA, active 42 mA	
Sensitivity (variable from sensor to sensor, typical values listed)	0.05 mV per W m ⁻²	0.15 mV per W m ⁻²	—	
Calibration Factor (reciprocal of sensitivity) (variable from sensor to sensor, typical values listed)	20 W m ⁻² per mV	6.7 W m ⁻² per mV	—	
Calibration Uncertainty	± 5 %			
Output Range	0 to 100 mV	0 to 300 mV	Modbus	
Measurement Range	0 to 2000 W m ⁻² (net shortwave radiation)			
Measurement Repeatability	Less than 1 %			
Long-term Drift	Less than 2 % per year			
Non-linearity	Less than 1 %			
Detector Response Time	0.5 s		—	
Field of View	180°	150°	180°	150°
Spectral Range (50 % points)	385 nm to 2105 nm	295 nm to 2685 nm	385 nm to 2105 nm	360 nm to 2250 nm
Directional (Cosine) Response	Less than 30 W m ⁻² at 80° solar zenith	Less than 20 % for angles between 0 and 60°	Less than 30 W m ⁻² at 80° solar zenith	Less than 10 % for angles between 0 and 60°
Temperature Response	Less than 5 % from -15 to 45 C			
Zero Offset A	Less than 5 W m ⁻² ; Less than 10 W m ⁻² (heated)		Less than 2 W m ⁻² ; Less than 5 W m ⁻² (heated)	
Zero Offset B	Less than 5 W m ⁻²			
Uncertainty with Daily Total	Less than 5 %			
Operating Environment	-50 to 80 C; 0 to 100% relative humidity			
Heater	390 Ω, 30.8 mA current draw and 370 mW power requirement at 12 V DC			
Dimensions	23.5 mm diameter, 28.7 mm height		66.5 mm height, 74.4 mm length, 33 mm height	
Mass (with 5 m of cable)	90 g	100 g	247 g	
Cable	5 m of four conductor, shielded, twisted-pair wire; additional cable available in multiples of 5 m; TPR jacket (high water resistance, high UV stability, flexibility in cold conditions); pigtail lead wires			
Warranty	4 years against defects in materials and workmanship			

Calibration Traceability

Apogee SP series pyranometers are calibrated through side-by-side comparison to the mean of four transfer standard sensors under a reference lamp. The reference sensors are recalibrated under sunlight in Logan, UT traceable to the World Radiometric Reference (WRR) in Davos, Switzerland.

Dimensions

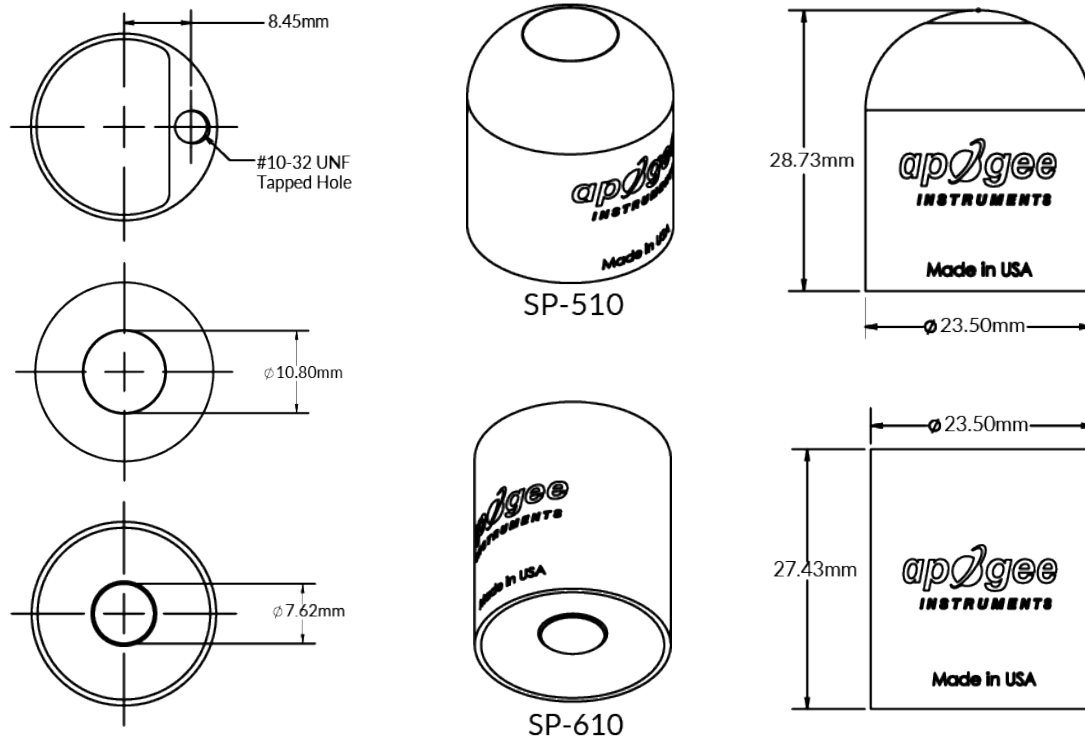

Features

TYPICAL APPLICATIONS

- Solar panel arrays
- Agricultural, ecological, and hydrological weather networks

STABLE MEASUREMENTS

Long-term non-stability determined from multiple replicate pyranometers in accelerated aging tests and field conditions is less than 2 % per year.

UNIQUE DESIGN

A patented dome-shaped sensor head keeps the sensor clean and minimizes errors by shedding water. Sensors are housed in a rugged anodized aluminum body and electronics are fully-potted.

MOUNTING OPTIONS

Mount the SP-710-SS with an AL-130 albedometer mounting bracket or an AM-130 albedometer mounting fixture with a 12" rod. The SP-722-SS is mounted using an AM-150 mounting bracket or AM-500 mounting bracket. The AM-150 may be used to mount sensors directly to a solar panel.

AL-130 Albedometer
Mounting Bracket



AM-130 Albedometer
Mounting Fixture with
12" Rod