



Product Specifications

	SL-510-SS	SL-610-SS
Sensitivity	0.12 mV per W m ⁻² (variable from sensor to sensor, typical value listed)	
Calibration Factor	8.5 W m ⁻² per mV (variable from sensor to sensor, typical values listed)	
Calibration Uncertainty	± 5 %	
Measurement Range	-200 to 200 W m ⁻² (net longwave irradiance)	
Measurement Repeatability	Less than 1 %	
Long-term Drift	Less than 2 % change in sensitivity per year	
Non-linearity	Less than 1 %	
Response Time	Less than 0.5 s	
Field of View	180°	150°
Spectral Range	5 to 30 μm	
Temperature Response	Less than 5 % from -15 to 45 C	
Window Heating Offset	Less than 10 W m ⁻²	
Zero Offset B	Less than 5 W m ⁻²	
Tilt Error	Less than 0.5 %	
Uncertainty with Daily Total	± 5 %	
Temperature Sensor	30 kΩ thermistor ± 1 C tolerance at 25 C	
Output from Thermistor	0 to 2500 mV (typical, other voltages can be used)	
Input Voltages Requirement for Thermistor	2500 mV excitation (typical, other voltages can be used)	
Heater	780 Ω, 15.4 mA current draw and 185 mW power requirement at 12 v DC	
Dimensions	27.5 mm height, 23.5 mm diameter	
Mass	90 g	100 g
Warranty	4 years against defects in materials and workmanship	



SL-510

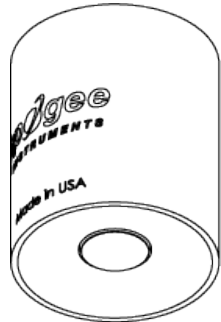
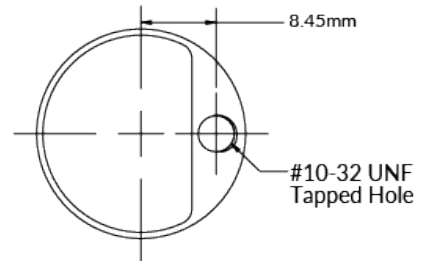
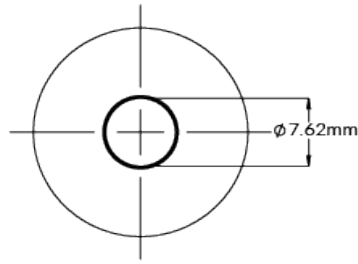
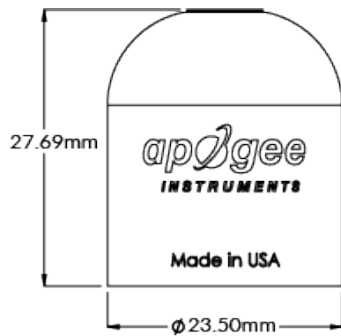

SL-610

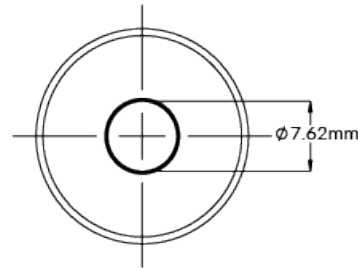
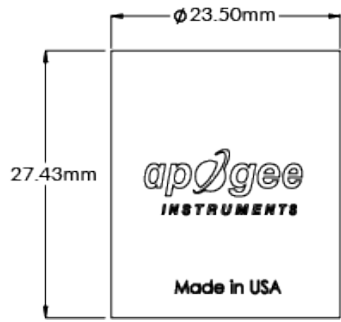

Features

Output Options

- 0 to 114 mV
- 0 to 2.5 V
- 0 to 5 V

Accurate, Stable Measurements

Long-term non-stability determined from multiple replicate pyrgeometers in accelerated aging tests and field conditions is less than 2 % per year.

Unique Design

Designed to optimize performance and price. The patented dome-shaped aluminum head is completely waterproof and minimizes errors by shedding water and dirt. All electronics are fully-potted.

On-board Heater

A 0.2 W heater keeps water off the sensor and minimizes errors caused by dew, frost, rain, or snow blocking the radiation path.

Typical Measurement Applications

- Longwave radiation measurement in agricultural, ecological, and hydrological
- Weather networks and renewable energy applications.

